



# WHEEL LOADERS

<b>DL200</b>	2.6 yd <sup>3</sup>	26,810 lb.	160 hp (119 kW)
<b>DL200Tc</b>	2.6 yd <sup>3</sup>	26,830 lb.	160 hp (119 kW)
<b>DL220</b>	3.0 yd <sup>3</sup>	28,350 lb.	160 hp (119 kW)
<b>DL250</b>	3.7 yd <sup>3</sup>	31,900 lb.	172 hp (128 kW)
<b>DL250Tc</b>	3.4 yd <sup>3</sup>	31,770 lb.	172 hp (128 kW)

2.5 – 4.0 yd<sup>3</sup>





# DOOSAN DELIVERS *a heritage of dedication*

DOOSAN, a strong, stable and global company with a 115-year legacy, has a heritage in equipment manufacturing that began in 1937. Since 2005, we've grown to become the fifth largest construction equipment manufacturer in the world.







Doosan can be found in every area of the infrastructure support business, which encompasses many facets of the heavy construction equipment industry.

Many contractors might be surprised to know that, while Doosan is a relatively young brand in the North American construction equipment market, the organization has a global manufacturing history going back more than 75 years.

Today, Doosan Infracore Construction Equipment America (DICEA) and its affiliates are industry leaders in the engineering, manufacturing and marketing of construction equipment including skid-steers, excavators, wheel loaders, articulated dump trucks, attachments, air compressors, lighting systems and generators as well as compact construction equipment and engine power systems.

### Building Your Tomorrow Today

Our construction equipment group leads Doosan's infrastructure support business (ISB) segment. Other ISB businesses include:

- Forklifts & Material Handling
- Machine Tools
- Castings & Forgings
- Construction & Engineering
- Power Generation
- Water Treatment & Desalination
- Renewable Energy

### Your North American partners.

Throughout our decades of selling equipment in North America, we've been building a network of dealers designed to surpass the standards for customer service. From coast to coast, there's a solid infrastructure that supports your equipment, including a parts distribution facility in Chicago and a service training facility in Georgia, sales training center in Arizona, attachments design and development in Minnesota and sales & marketing support in North Dakota.





# DOOSAN DELIVERS *Performance*



## **Optimized Engine Horsepower**

A finely tuned horsepower curve and increased torque ensure you can move mountains of material fast. A high pressure common rail fuel injection system and Cooled Exhaust Gas Recirculation (CEGR) valve reduce emissions.



## **Outstanding Traction and Pushing Power**

Doosan axles are carefully designed to maximize traction, provide easy maneuverability and generate excellent pushing power, making short work of even the biggest pile.

**Limited Slip Differential** allows the wheel with the most traction to receive the proper torque, providing superior tractive effort and maneuverability in tough terrain.



In your Doosan wheel loader cabin, even the most brutal workday looks better. That's because you have tremendous lift height and capacity, enough torque to bite into the toughest materials and power to spare to cut your toughest jobs down to size in a hurry. Scoop, carry material, load trucks... and even run attachments. Long days and tough jobs are easy – and profitable – in a Doosan wheel loader.

### Lift Capacity

There's no secret to doing more work in less time. You have to quickly and efficiently handle the biggest, heaviest load that you can. With its load-sensing, closed center hydraulics, Doosan wheel loaders deliver superior lift capacities for every model size.

**Self-Adjusting Brakes** increase performance and minimize maintenance. If needed, a technician can easily check the brakes and adjust externally. The brake piping is safely integrated with the axle housing and protected from jobsite debris.

**Optional Front-Locking Differential** locks the front left and right wheels together, providing superior traction for driving over loose, slippery terrain or pushing into big, heavy piles.

### Power Modes

Choose from three different power modes to change machine performance for job conditions or to reduce fuel consumption.

**Power Mode** delivers the highest level of performance for quick loading and fast travel. Finish more heavy-duty work in less time.

**Normal Mode** is ideal for general work conditions and optimal fuel consumption.

**Economy Mode** minimizes fuel consumption and reduces engine sound levels, providing for comfortable, economical light-duty work.

### Planetary Final Drives

The planetary final drives transfer torque to the wheels through the transmission and differential. They enable higher travel speeds and great torque reduction. The outboard, hub mounted design makes maintenance easy.





# DOOSAN DELIVERS *Productivity*

Productivity is what it's all about – and Doosan delivers. Whether you're loading a small truckload or moving a mountain of material, your Doosan wheel loader will leave you feeling good about the results at the end of the day.



### Interim Tier 4 (iT4) Compliant

Optimized to provide the ultimate in power delivery and fuel economy, Doosan wheel loaders are designed with iT4 compliant engines to reduce air pollution.

### Cooled Exhaust Gas Recirculation (CEGR)

CEGR recycles a portion of the engine exhaust to reduce oxygen and lower the temperature in the combustion chamber. This greatly reduces nitrogen oxide emissions (NOX).

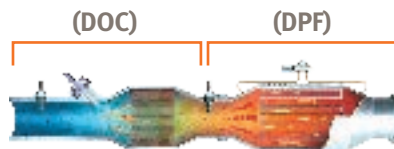

### Diesel Oxidation Catalyst (DOC)

Using DOC technology, particulate matter (PM) emissions are transformed into harmless water and carbon dioxide.

### Diesel Particulate Filter (DPF)

Exhaust enters the DPF where it's filtered further. The result is cleaner diesel exhaust and a healthier environment.

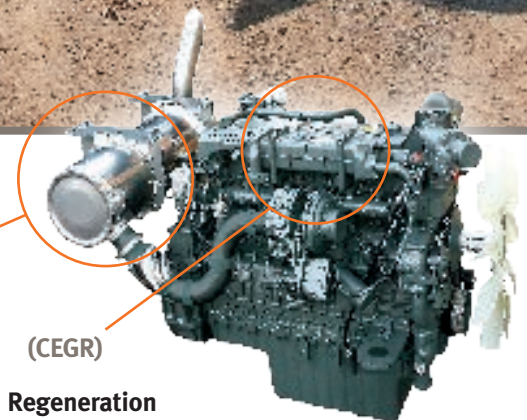

(CEGR)

### Regeneration

The DPF requires continuous regeneration to filter exhaust properly. Passive regeneration occurs with exhaust heat only. An active regeneration initiates automatically if the ECU detects certain levels of particulate matter in the DPF. It does not interfere with normal machine operation. If required, manual regeneration can be initiated by the operator.





### Fast Cycle Times

Speed and control are the keys to optimal production. Doosan wheel loaders are engineered to perfectly balance both. Durable, low-maintenance vane pumps deliver the power you need to complete every job quickly.

### FNR Joystick

Direction changes don't get any simpler. Just push the joystick buttons to switch between forward, neutral and reverse without even removing your hands from the controls.



### Optional Load Isolation System

The load isolation system, sometimes referred to as "ride control," cushions the lift arm while traveling over rough terrain, minimizing the loss of material while carrying a load and reducing operator fatigue. It also comes in handy when your customers pay for material by the bucket.

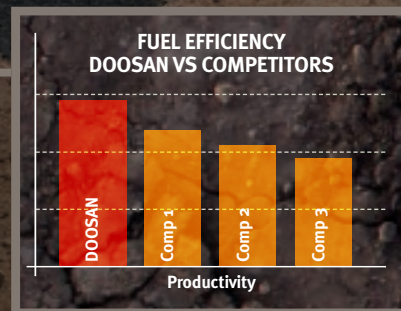

### Fuel efficiency

Fuel use is a significant cost of operation, and Doosan efficiently delivers more work for the money. In our fuel efficiency tests against equivalent machines from other manufacturers, the Doosan wheel loader consistently moves more material per gallon of fuel.



# DOOSAN DELIVERS *Productivity*



Whether you're loading a small truckload or moving a mountain of material, Doosan delivers amazing results in less time.

## **Return to Dig**

Sensors on the lift arm and bucket linkage allow you to change your "return to dig" setting from inside the cab. The cylinders and cutting edge return to the same position every time, enabling more efficient, consistent work.

## **Lift Kickout**

Set the maximum lift height for working inside buildings or other areas with height restrictions. Simply pull back on the control stick to override.

**Z-Bar Lift Arm Linkage** is designed for heavy lifting in loading applications, with geometry that enables rapid bucket movement and proper angle positioning in every situation.

**Standard Z-Bar** has excellent break-out forces for easier digging and penetration into tough materials. It increases the lifting capacity of every Doosan loader for best-in-class performance.



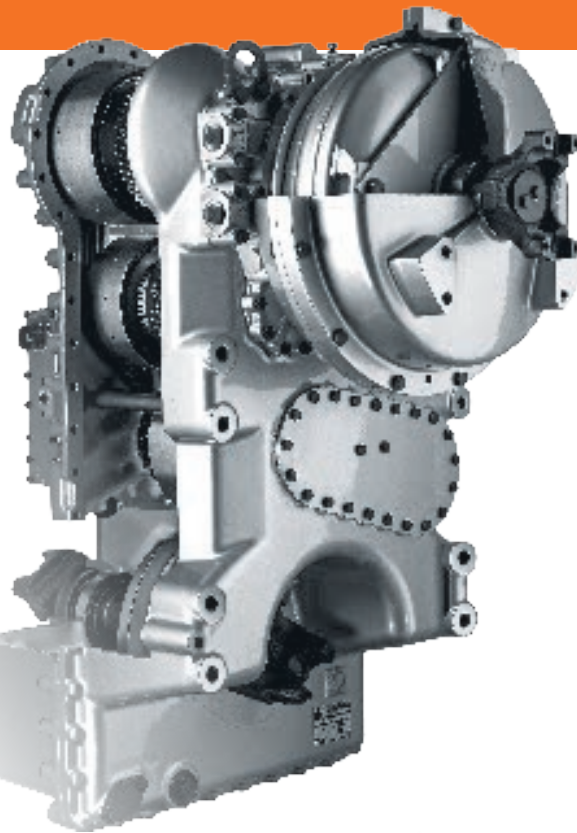

### Transmission Modes

With three separate transmission modes, you can choose the transmission you want for the working conditions you face, making it easy to tailor performance for better productivity.

**Transmission Optimization** is a key feature of the automatic transmission modes. It calibrates different shift points to tailor the amount of power and engine torque per gear. When you engage either Auto 1-4 or Auto 2-4 in Power Mode or Normal Mode, the transmission shift point occurs 20% later—allowing more torque and power within each gear range. In Economy Mode, the automatic transmission shifts 20% earlier for increased fuel efficiency.

**Manual** is ideal when the job requires precise speed control.

**Auto 1-4** automatically shifts up when you need more speed and downshifts when the job demands more power or torque. It's excellent for heavy-duty applications.



**Auto 2-4 with Manual Kickdown** gives you automatic shifting between gears 2 through 4, with a manual downshift into first gear when you need it. It provides the best performance for less demanding work conditions.

### Transmission Cutout

Need more engine power for lift arm speed? In lower gears, simply depress the left brake pedal to disengage the transmission. Disengage transmission cutout with your switch panel to start moving on an incline with greater ease.

### Torque Converter

The torque converters improve power train efficiency in load and carry operations, which contributes to improved fuel efficiency.

### Auto idle

The standard auto idle feature automatically reduces the engine rpm to standby idle a few seconds after the steering wheel, gearshift control lever and accelerator cease movement. This reduces noise, improves jobsite communications and saves fuel. When you move the controls, the loader automatically returns to working idle.

### An optional hydraulic coupler

increases your productivity with non-hydraulic attachments, such as the pallet fork, saving you time by enabling you to switch from one attachment to the next without even leaving the cab.



**High Lift Z-Bar** is optional and designed for applications requiring the highest possible dumping height and reach. It's ideal for cement plants, scrap, mulch or wastewater transfer stations.

**Parallel Lift Linkage** is designed to give you precise control over the movement of buckets, pallet forks and other attachments in applications other than loading. This design keeps the attachment level, allowing for faster lifting and placing of materials.



# DOOSAN DELIVERS *Durability/Reliability*



When you get up close to a Doosan wheel loader, you can see that this machine is built to last. With heavy-duty parts, quality materials and superb construction, you can rely on performance, productivity and profit day after day. Plus, innovative designs keep you on the job with fewer service intervals – so you spend less time in the shop.







### Tough, Rigid Frame

Each frame section is designed to maximize the life of the machine. Thick steel plates, cross members and gussets join to form a strong, durable articulation joint that stands up to years of difficult work.



### Double Roller Articulation Joint Bearing

To create an articulation pivot point with superior strength, tough double roller bearings are used at both the top and bottom hinge points between the front and rear frames.



### Large Center Driveline Bearing

An oversized bearing, that is vented to prevent over greasing, increases durability of the front drive shaft.



### All-Steel Panels

Access panels on Doosan wheel loaders allow easy maintenance access and they're made of durable formed metal to protect critical engine, hydraulic and electrical components.



### Lift Arm Pin Protection

Lift arm pins are protected with bushings and dust covers to increase pin life and reduce maintenance.

### Variable Speed Cooling Fan

The variable speed fan slows and speeds up as required by the work demands of your loader. In lighter-duty conditions the coolant temperature is low and the fan slows – saving fuel and extending the life of your cooling system.

### Reversible Cooling Fan

By pressing a console switch, the cooling fan can be reversed to assist in keeping the cooling system clean in extremely dusty applications. Press it to keep the machine running at optimal temperature. You can also set it to auto reverse for a few minutes at a time at different intervals – at 30, 60, 90 or 120 minutes depending on work conditions.

### Separate Cooling and Engine Compartments

Doosan isolates the wheel loader engine from the cooling system. This design increases cooling capacity and extends the life of your engine components.

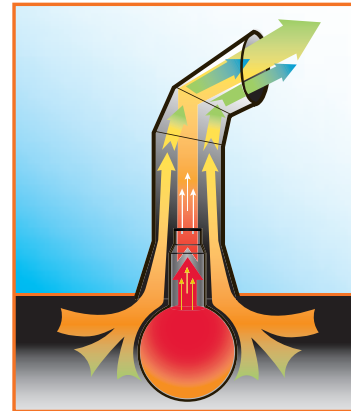

### Exhaust heat exchanger

As exhaust leaves the muffler on your Doosan wheel loader, it enters a larger external riser pipe with rain shield. This design creates a vacuum that pulls hot air out of the engine compartment, making your engine run and cooling system run more efficiently.

### Thick Lift Arm Plates

Thick, solid-steel lift arm plates provide maximum durability in harsh conditions – along with improved lift capacities. A narrower arm design overall increases your visibility.



# DOOSAN DELIVERS *Comfort*

You can't overlook the relationship between comfort and productivity. That's why comfort is central to the Doosan cabin design. It's packed with high-end comfort that enables you to retain a team of productive, experienced and satisfied employees.

## **Quiet Operation**

Operators stay relaxed and focused on the job with a quiet operating environment. Noise levels in the cabin stay below a comfortable 72 decibels, thanks to the variable speed cooling fan, double-walled muffler, soundproof materials throughout the engine compartment and tightly sealed & pressurized cabin.

## **Excellent Visibility**

Large front and rear glass surface areas provide an excellent view to the loader workgroup and jobsite. Narrow corner pillars and small window joints increase visibility to the front of the machine. Heated mirrors provide visibility to the sides and rear of the machine, even in cold temperatures.



### Easy Entry and Exit

Grab handles and offset steps with slip-resistant surfaces provide easy access to the cabin and easy exit when work is finished. A 180-degree swinging door that can lock to the open position provides a wide opening to move in and out of the machine. Inside, ample floor space gives you room to work and exceptional comfort.

### Ergonomic Controls

All controls are located within easy reach for intuitive, easy operation, from the steering wheel and joystick to the switches for optional equipment.



### Optional Rearview Camera

Provides the operator with an additional means to view the machine's surroundings, allowing for increased productivity.

### Automotive-Style Heat and Air Conditioning

Stay comfortable all year with high capacity heating and cooling vents and an easy-to-control temperature. Automatic temperature control senses and adjusts to the temperature setting automatically. A memory function returns it to your preferred temperature if you shut the machine off and restart later.

### Easy-to-Read LCD Display Panel

An easy-to-read LCD display panel is placed within easy view for monitoring critical machine data and receiving machine warnings.



### Standard Radio with CD-player and MP3-player Input

Tune into your favorite over-the-air stations, or take your favorite digital music format with you to work, to make every hour on the job more enjoyable.

### Adjustable Comfort

The standard air suspension seat has multiple adjustment points, allowing you to select the most comfortable position.

- A Seat Height
- B Seat Fore/Aft
- C Back Recline
- D Lumbar Support
- E Armrest Angle
- F Seat Heater (Opt.)
- G Headrest Up/Down





# DOOSAN DELIVERS *Easy Maintenance*

If it's easy to do, regular maintenance gets done – and you'll get more production and efficiency from your loader. That's how Doosan approaches maintenance. First, we build the machine tough for long-lasting performance and longer service intervals. Next we make machine care second-nature to every operator with centrally located maintenance points, onboard diagnostic systems and easy component access. If you want durability and simple maintenance, Doosan delivers.

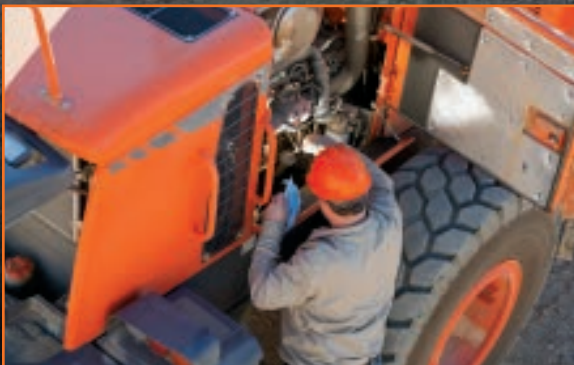

## **Easy Component Access**

Big, easy-to-open access covers and fold-up panels provide fast, ground-level access to critical engine and hydraulic components. When it's easy to reach and service components, you save time on maintenance and reduce your operating costs.



### Doosan Telematics (GPS)

A simple user interface, accessible online via a web-enabled computer or cell phone, provides location information and a full range of machine operational information to you, your dealer and Doosan, allowing a complete machine maintenance management strategy to reduce operating costs.



### Sight Glass for Major Fluid Levels

Sight glasses on the machine provide quick, easy fluid-level checks. All it takes is a quick visual check to know if your fluid reservoirs are properly filled.



### Centralized Remote Hydraulic Diagnostic Ports

You can review pressure and troubleshoot hydraulic issues from one check port bank. In minutes you can review pilot charge, brake system charge, load sensing, steering system, fan and steering pressures, along with the main relief setting.



### Color-Coded, Labeled Wiring and Hydraulic Hoses

Strategically labeled wiring enables plug-and-play installation electrical accessories, such as the rotating beacon. It also allows quicker, easier electrical troubleshooting of the electrical and hydraulic systems.

### Self-Diagnostics

The LCD monitor helps you monitor critical systems in real time. Plus, you can access historical machine alerts right from the screen in the cabin.



### Doosan Monitoring System with Laptop Access

The Doosan Monitoring System is a diagnostic program that gives your dealer's technician a direct communications link with your wheel loader. During operation, it monitors all critical data and provides a complete history of operation and a real-time log of machine failures. Armed with information like this, your dealer service personnel can fix issues fast—and you can get back to work.

### Remote Drain Ports

Easy-to-access remote drain valves make for fast, convenient exchanges of engine oil and cooling system coolant.

### Remote Grease Points

For a long-lasting machine, daily maintenance is critical. Remote grease points make it easier to lubricate hard-to-reach pins on the lift arm and articulation system. Daily greasing happens on the ground – and it's more likely to get done.





# DOOSAN DELIVERS *Versatility*

Do more with your machine. Doosan loaders are optimized for attachment versatility – bringing you more opportunities to utilize your equipment investment, and possibly enabling you to expand your business. Our tough attachments are matched to your machine’s operator weight and load settings – so you can rely on epic productivity with every job.

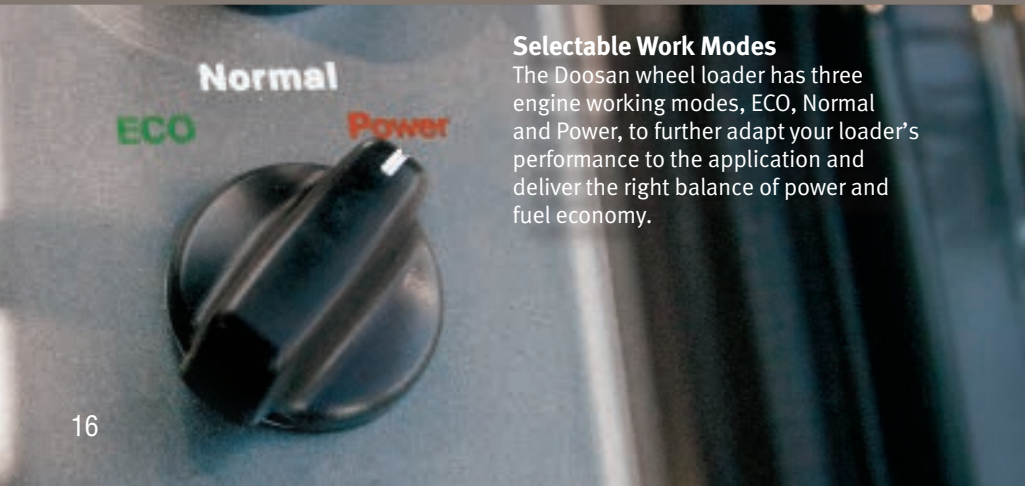

### Selectable Work Modes

The Doosan wheel loader has three engine working modes, ECO, Normal and Power, to further adapt your loader’s performance to the application and deliver the right balance of power and fuel economy.

### Standard Attachment Hydraulics

For hydraulic attachments, like the multi-purpose bucket, an auxiliary spool for hydraulic attachments comes standard. No extra installation required. Hydraulic lines down the boom are optional.

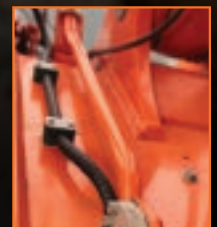





#### Optional Quick Coupler

Quickly change many of your wheel loader's non-hydraulic attachments without leaving the seat. A four-point style pick-up means you can hook up attachments easily, even on irregular terrain.

#### Boom Float

The boom float allows your bucket to follow the ground contours, which saves you time and increases productivity when backdragging during snow removal.





# DOOSAN DELIVERS *Attachments*

## General Purpose Bucket



With a sloped bottom for maximum filling and material retention, this is the perfect bucket for day-to-day material handling. Capacities range from 4 to 6.5 yd<sup>3</sup>.

Available for DL200-3, DL200TC-3, DL220-3, DL250-3 and DL250TC-3 wheel loaders. All available with bolt-on cutting edge or teeth.

Pin-On

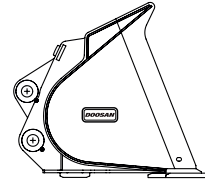

Quick Coupler

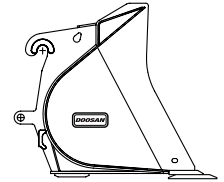

## Light Material Bucket



When you need to move snow, mulch or other light material in a hurry, the light material bucket is the economical choice. Comes standard with bolt-on cutting edge.

Available for DL200-3, DL200TC-3, DL220-3, DL250-3, and DL250TC-3 wheel loaders. All available with bolt-on cutting edge.

Pin-On

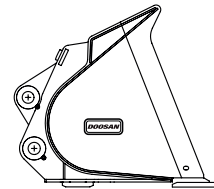

Quick Coupler

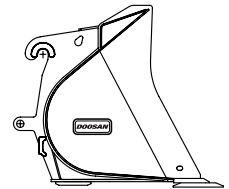

## Multi-Purpose Bucket



Leveling, dozing, digging, grappling, loading and dumping—this multi-purpose bucket is ready for whatever you've got. Capacities from 3.5 to 4 yd<sup>3</sup>.

Available for DL200-3, DL200TC-3, DL220-3, DL250-3 and DL250TC-3 wheel loaders. All available with bolt-on cutting edge or teeth.

Pin-On

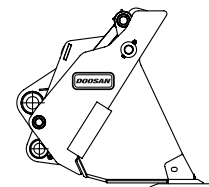

Quick Coupler

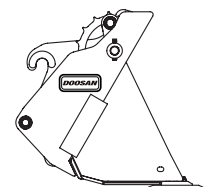

## Pallet Fork



Easily lift, carry and place materials. Pallet forks with 48" or 60" forks available for DL200-3, DL200TC-3, DL220-3, DL250-3 and DL250TC-3 wheel loaders.

Quick Coupler

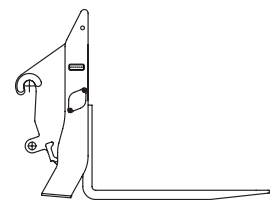

*Quick couplers are available in two designs – JRB and ISO style.  
For more information on Doosan attachments, refer to the Doosan Wheel Loader Attachment literature.*



## General Specs

			DL200-3	DL200TC-3	DL220-3	DL250-3	DL250TC-3
<b>ENGINE</b>							
Model			Doosan DL06	Doosan DL06	Doosan DL06	Doosan DL06	Doosan DL06
NUMBER OF CYLINDERS			6	6	6	6	6
RATED POWER, GROSS <i>(per SAE J1995)</i>			hp (kW) @ rpm	160 (119) @2100	160 (119) @2100	160 (119) @ 2100	172 (128) @ 2100
MAXIMUM TORQUE, GROSS <i>(per SAE J1995)</i>			ft.-lb. (Nm) @ RPM	542 (735) @ 1400	542 (735) @ 1400	542 (735) @ 1400	593 (804) 1400
PISTON DISPLACEMENT			in <sup>3</sup> (L)	360 (5.9)	360 (5.9)	360 (5.9)	360 (5.9)
BORE AND STROKE			in. x in. (mm x mm)	3.9 x 4.9 (100 x 125)	3.9 x 4.9 (100 x 125)	3.9 x 4.9 (100 x 125)	3.9 x 4.9 (100 x 125)
STARTER			V, hp (Kw)	24, 6	24, 6	24, 6	24, 6
BATTERY			V, AH, CCA	24, 100, 1050	24, 100, 1050	24, 100, 1050	24, 100, 1050
ALTERNATOR			V, amp	24, 60	24, 60	24, 60	24, 60
AIR CLEANER				Double Element	Double Element	Double Element	Double Element
<b>HYDRAULICS</b>							
SYSTEM PRESSURE (WORK)			psi (bar)	3626 (250)	3626 (250)	3626 (250)	3626 (250)
SYSTEM PRESSURE (STEER)			psi (bar)	3626 (250)	3626 (250)	3626 (250)	3626 (250)
BOOM SPEED	UP (UNLOADED)	sec.	5.6	5.7	6.0	6.0	5.8
	DOWN	sec.	3.5	3.7	3.5	2.7	2.9
BUCKET SPEED	CROWD (UNLOADED)	sec.	1.7	2.2	1.9	1.9	2.1
	DUMP	sec.	1.1	3.4	1.3	1.3	2.9
<b>ENVIRONMENT</b>							
SOUND LEVEL <i>(per ISO 6394)</i>			dB(A)	103	103	103	104
CABIN SOUND LEVEL <i>(per ISO 6394)</i>			dB(A)	72	72	72	72
<b>TRANSMISSION SPEEDS</b>							
TRAVEL SPEED - FORWARD (4)			mph (km/h)	4.4 / 8.0 / 15.1 / 23.6 (7.1 / 12.8 / 24.3 / 38.0)	4.4 / 8.0 / 15.1 / 23.6 (7.1 / 12.8 / 24.3 / 38.0)	4.4 / 8.0 / 15.1 / 23.6 (7.1 / 12.8 / 24.3 / 38.0)	5.0 / 8.5 / 16.5 / 23.6 (8.1 / 13.7 / 26.5 / 38)
TRAVEL SPEED - REVERSE (3)			mph (km/h)	4.7 / 8.4 / 15.8 (7.5 / 13.5 / 25.5)	4.7 / 8.4 / 15.8 (7.5 / 13.5 / 25.5)	4.7 / 8.4 / 15.8 (7.5 / 13.5 / 25.5)	5.3 / 8.9 / 17.2 (8.5 / 14.4 / 27.7)
MAXIMUM GRADE			% (°)	58 (30)	58 (30)	58 (30)	58 (30)
<b>REFILL CAPACITIES</b>							
FUEL TANK			gal. (L)	62 (235)	62 (235)	62 (235)	67 (255)
COOLING SYSTEM (RADIATOR)			gal. (L)	11 (40)	11 (40)	11 (40)	11 (40)
ENGINE OIL			gal. (L)	7.1 (27)	7.1 (27)	7.1 (27)	7.1 (27)
TRANSMISSION			gal. (L)	7.9 (30)	7.9 (30)	7.9 (30)	12 (45)
FRONT AXLE			gal. (L)	5.7 (21.5)	5.7 (21.5)	5.7 (21.5)	9.3 (35)
REAR AXLE			gal. (L)	5.7 (21.5)	5.7 (21.5)	5.7 (21.5)	5.7 (21.5)
HYDRAULIC SYSTEM			gal. (L)	38 (142)	38 (142)	38 (142)	47 (176)
<b>Hydraulic Cylinders</b>							
STEERING (2)	BORE	in. (mm)	2.75 (70)	2.75 (70)	2.75 (70)	2.8 (70)	2.8 (70)
	ROD	in. (mm)	1.4 (35)	1.4 (35)	1.4 (35)	1.8 (45)	1.8 (45)
	STROKE	in. (mm)	14.6 (370)	14.6 (370)	14.6 (370)	18.3 (466)	18.3 (466)
LIFT (2)	BORE	in. (mm)	4.3 (110)	4.3 (110)	4.5 (115)	5.1 (130)	5.1 (130)
	ROD	in. (mm)	3 (75)	3 (75)	3 (75)	3.1 (80)	3.1 (80)
	STROKE	in. (mm)	31.1 (790)	31.1 (790)	31.1 (790)	31.0 (785)	31.0 (785)
BUCKET (1) *	BORE	in. (mm)	4.7 (120)	4.1 (105)	5.1 (130)	5.7 (145)	4.3 (110)
	ROD	in. (mm)	3 (75)	2.6 (65)	3 (75)	3.1 (80)	2.6 (65)
	STROKE	in. (mm)	20.3 (515)	33.2 (843)*	20.3 (515)	20.1 (510)	34.7(881)*

\* The DL200TC-3 and DL250TC-3 have 2 bucket cylinders.

NOTE — Where applicable, dimensions are in accordance with Society of Automotive Engineers (SAE) and ISO standards. Specifications and design are subject to change without notice. Pictures of Doosan wheel loaders may show other than standard equipment. All dimensions are shown in inches. Respective metric dimensions are enclosed by parentheses. Doosan Construction Equipment is manufactured with a Quality Management System that is in compliance with ISO 9001:2008.

All Dimensions are given for Doosan wheel loaders equipped with standard tires.



## Operational Data

			DL200-3	DL200-3 HL	DL200TC-3
BUCKET TYPE: General Purpose	BUCKET MOUNT: Pin On		BUCKET CONFIGURATION: Bolt-On Edge		
CAPACITY HEAPED ISO / SAE		yd3 (m3)	2.6 (2.0)	2.6 (2.0)	2.6 (2.0)
BUCKET WIDTH	A	ft. in. (mm)	8'4" (2550)	8'4" (2550)	8'4" (2550)
HINGE PIN HEIGHT, MAXIMUM	B	ft. in. (mm)	12'8" (3860)	13' 11" (4240)	12' 6" (3810)
DUMP HEIGHT (45 °) - FULLY RAISED	C	ft. in. (mm)	9'6" (2890)	10' 9" (3270)	8' 10" (2685)
DUMP REACH (45 °) - FULLY RAISED	D	ft. in. (mm)	3'3" (1000)	3' 5" (1040)	3' 1" (945)
DIGGING DEPTH	E	ft. in. (mm)	4" (90)	8" (200)	3" (75)
OVERALL HEIGHT, ROPS CABIN	F	ft. in. (mm)	10'9" (3280)	10'9" (3280)	10'9" (3280)
OVERALL LENGTH	G	ft. in. (mm)	23'9" (7245)	25' 7" (7795)	24'0" (7315)
WHEEL BASE	H	ft. in. (mm)	9'6" (2900)	9'6" (2900)	9'6" (2900)
WIDTH AT TIRES	I	ft. in. (mm)	8'4" (2530)	8'4" (2530)	8'4" (2530)
TREAD WIDTH	J	ft. in. (mm)	6'4" (1930)	6'4" (1930)	6'4" (1930)
GROUND CLEARANCE	K	ft. in. (mm)	1'5" (435)	1'5" (435)	1'5" (435)
MAX. TILT ANGLE ON GROUND		°	42	43	46
MAX. TILT ANGLE AT CARRY POSITION	L	°	48	51	48
MAX. TILT ANGLE AT FULLY RAISED	M	°	59	61	53
MAX. DUMP ANGLE (FULLY RAISED)	N	°	48	46	47
STEERING ANGLE, MAXIMUM	O	°	40	40	40
EXTERNAL RADIUS, BUCKET EDGE	P	ft. in. (mm)	19'0" (5785)	19'7" (5969)	18'11" (5770)
EXTERNAL RADIUS, OUTSIDE TIRE	Q	ft. in. (mm)	17'2" (5245)	17'2" (5245)	17'2" (5245)
TIRE SIZE			20.5-25	20.5-25	20.5-25
OPERATING WEIGHT		lb. (kg)	26,810 (12 160)	28,000 (12 720)	26,830 (12 170)
STATIC TIPPING LOAD (STRAIGHT)		lb. (kg)	19,750 (8960)	17,920 (8130)	17,950 (8140)
STATIC TIPPING LOAD (AT FULL TURN)		lb. (kg)	17,110 (7760)	15,520 (7040)	15,540 (7050)
BREAKOUT FORCE		lbf. (kg)	22,230 (10 083)	22,030 (9993)	23,040 (10 452)

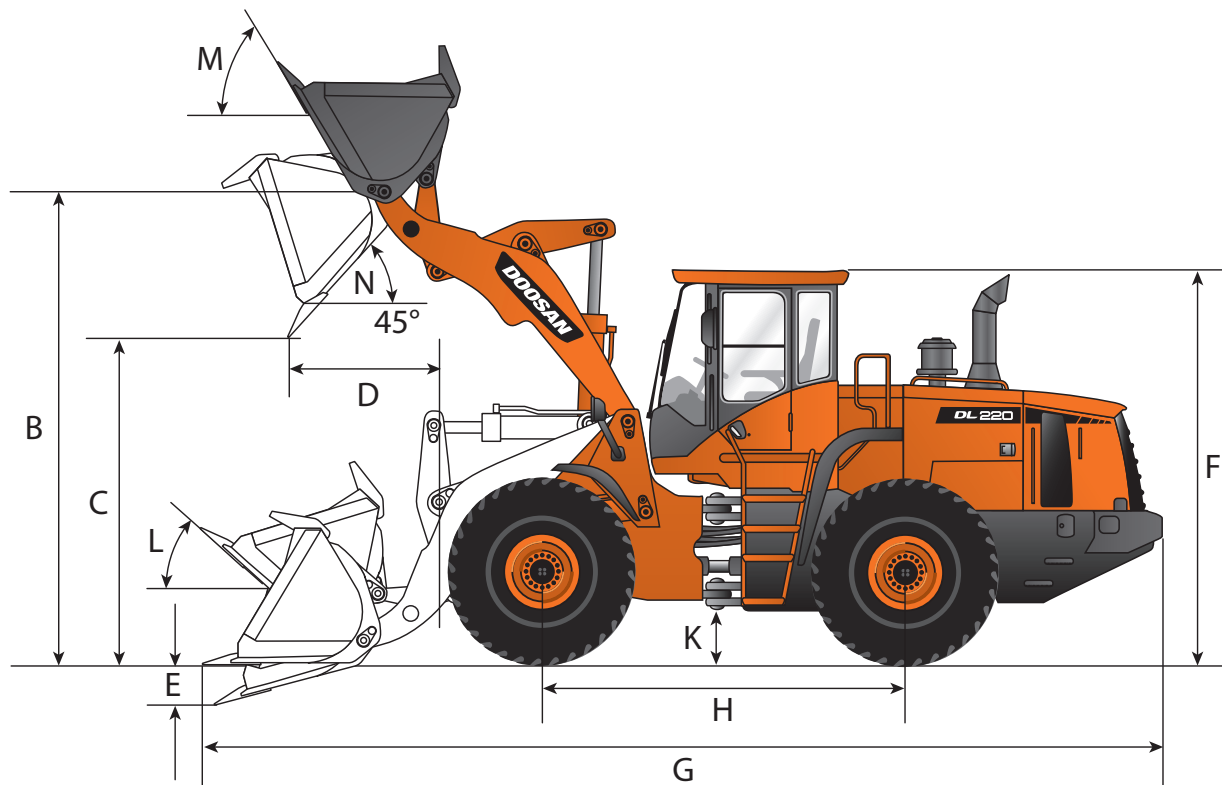



# Operational Data *Continued*

		DL220-3	DL250-3	DL250-3 HL	DL250TC-3	
BUCKET TYPE: General Purpose		BUCKET MOUNT: Pin On		BUCKET CONFIGURATION: Bolt-On Edge		
CAPACITY HEAPED ISO / SAE		yd3 (m3)	3.0 (2.3)	3.7 (2.8)	3.4 (2.6)	3.4 (2.6)
BUCKET WIDTH	A	ft. in. (mm)	8'4" (2550)	9'0" (2740)	9'0" (2740)	9'0" (2740)
HINGE PIN HEIGHT, MAXIMUM	B	ft. in. (mm)	12'8" (3860)	12'10" (3900)	14'2" (4325)	12'11" (3935)
DUMP HEIGHT (45 °) - FULLY RAISED	C	ft. in. (mm)	9'3" (2825)	9'2" (2785)	10'8" (3250)	9'0" (2740)
DUMP REACH (45 °) - FULLY RAISED	D	ft. in. (mm)	3'6" (1065)	3'11" (1190)	3'10" (1175)	4'3" (1300)
DIGGING DEPTH	E	ft. in. (mm)	3" (88)	5" (115)	8" (215)	3" (85)
OVERALL HEIGHT, ROPS CABIN	F	ft. in. (mm)	10'9" (3280)	10'9" (3280)	10'9" (3280)	10'9" (3280)
OVERALL LENGTH	G	ft. in. (mm)	24'7" (7485)	25'2" (7665)	26'10" (8180)	25'9" (7840)
WHEEL BASE	H	ft. in. (mm)	9'6" (2900)	9'11" (3020)	9'11" (3020)	9'11" (3020)
WIDTH AT TIRES	I	ft. in. (mm)	8'4" (2530)	8'8" (2640)	8'8" (2640)	8'8" (2640)
TREAD WIDTH	J	ft. in. (mm)	6'4" (1930)	6'8" (2040)	6'8" (2040)	6'8" (2040)
GROUND CLEARANCE	K	ft. in. (mm)	1'5" (435)	1'4" (415)	1'4" (415)	1'4" (415)
MAX. TILT ANGLE ON GROUND		°	42	43	40	43
MAX. TILT ANGLE AT CARRY POSITION	L	°	48	49	48	48
MAX. TILT ANGLE AT FULLY RAISED	M	°	59	61	58	51
MAX. DUMP ANGLE (FULLY RAISED)	N	°	48	47	46	50
STEERING ANGLE, MAXIMUM	O	°	40	40	40	40
EXTERNAL RADIUS, BUCKET EDGE	P	ft. in. (mm)	19'1" (5815)	20'0" (6085)	20'7" (6285)	19'1" (5815)
EXTERNAL RADIUS, OUTSIDE TIRE	Q	ft. in. (mm)	17'2" (5245)	18'0" (5475)	18'0" (5475)	18'0" (5475)
TIRE SIZE			20.5-25	20.5-25	20.5-25	20.5-25
OPERATING WEIGHT		lb. (kg)	28,350 (12 860)	31,900 (14 470)	32,780 (14 870)	31,770 (14 410)
STATIC TIPPING LOAD (STRAIGHT)		lb. (kg)	21,340 (9680)	23,810 (10 800)	20,920 (9490)	19,690 (8930)
STATIC TIPPING LOAD (AT FULL TURN)		lb. (kg)	18,480 (8380)	20,680 (9380)	18,170 (8240)	17,130 (7770)
BREAKOUT FORCE		lbf. (kgf)	23,650 (10 727)	27,120 (12 380)	25,680 (11 645)	25,980 (11 784)

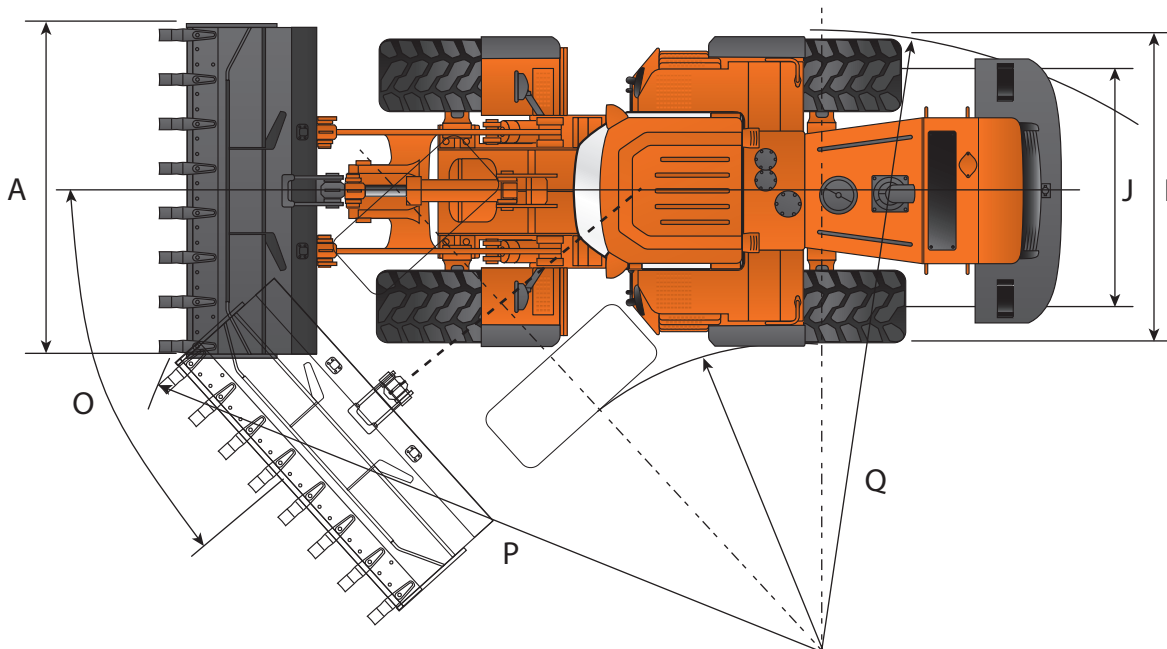



## Standard/Optional Equipment

	DL200-3	DL200TC-3	DL220-3	DL250-3	DL250TC-3
<b>ENGINE</b>					
Emissions (EPA)	iT4	iT4	iT4	iT4	iT4
Cooled Exhaust Gas Recirculation (CEGR)	•	•	•	•	•
Diesel Particulate Filter (DPF)	•	•	•	•	•
High Pressure Common Rail (HPCR)	•	•	•	•	•
Fuel Filter with Water Separator	•	•	•	•	•
Coolant Recovery tank	•	•	•	•	•
Dual Element dry-type air filter with Evacuator	•	•	•	•	•
Pre Cleaner	•	•	•	•	•
Electronic Engine Control	•	•	•	•	•
Auto-Idle (Working to Standby)	•	•	•	•	•
Overheat & Low Oil Pressure Engine Protection	•	•	•	•	•
Cooling Fan, Variable Speed	•	•	•	•	•
Cooling Fan, Automatic Reversible	•	•	•	•	•
Block Heater	•	•	•	•	•
<b>HYDRAULIC</b>					
Variable Displacement Axial Piston Pump	•	•	•	•	•
Closed-Center System	•	•	•	•	•
Pilot Operated Control Valves	•	•	•	•	•
Remote Test Ports	•	•	•	•	•
Spring Applied Hydraulic Release Brake	•	•	•	•	•
Auxiliary Hydraulics (3rd Valve)	•	•	•	•	•
Auxiliary Hydraulics (4th Valve)	•	•	•	•	•
Automatic Boom/Lift Kick-Out, Adjustable (in cab)	•	•	•	•	•
Automatic Return-to-Dig Position, Adjustable	•	•	•	•	•
Boom Float	•	•	•	•	•
Load Isolation System	•	•	•	•	•
<b>ELECTRICAL</b>					
Alternator - 12V, 80 Amp	•	•	•	•	•
2 x 12V Batteries, 100 AH Reserve Capacity	•	•	•	•	•
Blade Type Fuse Panel	•	•	•	•	•
Main Circuit Breaker	•	•	•	•	•
Light, Work (Halogen): Front (2), Rear (2)	•	•	•	•	•
Light, Headlights (High/Low Beams) (2)	•	•	•	•	•
Light, Stop, Tail & Direction Indicators	•	•	•	•	•
Rotating Beacon	•	•	•	•	•
Hour Meter	•	•	•	•	•
Rear View Camera	•	•	•	•	•
Laptop Service Port	•	•	•	•	•
Self-Diagnostics System	•	•	•	•	•
Telematics	•	•	•	•	•

	DL200-3	DL200TC-3	DL220-3	DL250-3	DL250TC-3
<b>CABIN</b>					
Steel, All-Weather & Sound Suppressed	•	•	•	•	•
ROPS (ISO 3471)	•	•	•	•	•
Front & Rear Window with Wiper/Washer	•	•	•	•	•
Tinted Safety Glass	•	•	•	•	•
Lockable Doors	•	•	•	•	•
Seat - Air Suspension - 2" (51 mm) Seat Belt - Adjustable Height & Recline - Adjustable Arm Rests"	•	•	•	•	•
Seat - Heated	•	•	•	•	•
3" (76 mm) Seat Belt	•	•	•	•	•
Control Stand - Sliding (Fore/Aft)	•	•	•	•	•
Storage	•	•	•	•	•
Mirrors, Rear View (2)	•	•	•	•	•
Mirrors, Exterior (2) Heated	•	•	•	•	•
Fully Automatic HVAC w/ ambient temperature sensor	•	•	•	•	•
Multi-Function LCD	•	•	•	•	•
Cigarette Lighter	•	•	•	•	•
AM/FM Stereo with CD Player & MP3 port	•	•	•	•	•
Speakers (2)	•	•	•	•	•
Antenna, Roof Mounted	•	•	•	•	•
Power Socket, 12V	•	•	•	•	•
Beverage Holder	•	•	•	•	•
Hot/Cold Compartment	•	•	•	•	•
Interior Light	•	•	•	•	•
Sun Visor	•	•	•	•	•
<b>CONTROLS</b>					
Adjustable steering column - Tilting - Telescoping	•	•	•	•	•
Throttle pedal (accelerator)	•	•	•	•	•
Brake Pedal, Right	•	•	•	•	•
Brake Pedal, Left (Transmission Kick out)	•	•	•	•	•
Gear Selector (FnR)	•	•	•	•	•
Joystick Control	•	•	•	•	•
Finger Tip Control (3 Lever)	•	•	•	•	•
Switches, Console mounted - Starter (Key) - Parking Brake - Pilot Cutoff - Transmission Cutoff - Work Light - DPF Regeneration - Reversible Cooling Fan	•	•	•	•	•
Power Mode (P, S, E)	•	•	•	•	•
Transmission Mode	•	•	•	•	•
Wiper Control Panel	•	•	•	•	•
Audio Control Panel	•	•	•	•	•

- Standard Equipment
- Optional Equipment
- N/A



# Standard/Optional Equipment *Continued*

	DL200-3	DL200TC-3	DL220-3	DL250-3	DL250TC-3		DL200-3	DL200TC-3	DL220-3	DL250-3	DL250TC-3
<b>DRIVELINE</b>						<b>OTHER</b>					
Transmission, Auto Power Shift (4F / 3R Speed)	•	•	•	•	•	Centralized Lubrication	•	•	•	•	•
Torque Converter	•	•	•	•	•	Handrails & Service Platforms	•	•	•	•	•
Limit Slip Differentials	•	•	•	•	•	Skid-Resistant Steps	•	•	•	•	•
Locking Front Differential	•	•	•	•	•	Drawbar and Pin	•	•	•	•	•
Hydraulic Power Steering	•	•	•	•	•	Wheel Chocks	•	•	•	•	•
Tires, 20.5R25 Bias	•	•	•	•	•	Rear Fender, Full	•	•	•	•	•
Tires, 20.5R25 Radial	•	•	•	•	•	Additional Counterweight <i>- Additional counterweight is standard on all High Lift machines.</i>	•	•	-	•	•
<b>DISPLAY MONITOR &amp; WARNINGS</b>						Manuals <i>- Operation &amp; Maintenance</i> <i>- Parts</i> <i>- AEM Safety Manual</i>	•	•	•	•	•
Buzzer <i>- Engine Oil Pressure</i> <i>- Coolant Temperature</i> <i>- Transmission Overheat</i>	•	•	•	•	•	Telematics, 1 Year Subscription	•	•	•	•	•
Gauges <i>- Engine Coolant Temperature</i> <i>- Fuel Level</i> <i>- Transmission Oil Temperature</i> <i>- Engine RPM</i> <i>- Speedometer</i> <i>- Battery Voltage</i> <i>- ECO</i> <i>- Digital Clock</i> <i>- Trip Meter</i> <i>- Hour Meter</i> <i>- Total Operation Time</i>	•	•	•	•	•	Vandalism Protection <i>- Lockable Panels</i> <i>- Lockable Fluid Fill Points</i>	•	•	•	•	•
Warning & Indicator Lights <i>- Engine Oil Pressure</i> <i>- Check Engine</i> <i>- Engine Pre-Heat Engaged</i> <i>- Air Filter</i> <i>- Transmission Mode</i> <i>- Emergency Steering</i> <i>- Battery Charge</i> <i>- Error Code</i> <i>- Direction Signal</i> <i>- Lights (High, Main, Work, Beacon)</i> <i>- Water in Fuel</i> <i>- DPF Regeneration</i> <i>- DPF High Temperature Exhaust</i> <i>- Transmission Warning</i> <i>- Hydraulic Charge Pressure Warning</i> <i>- Brake Fluid Pressure Warning</i> <i>- Transmission Gear &amp; F-N-R</i> <i>- Reverse Fan Indicator</i> <i>- Mirror Heat Indicator</i> <i>- Parking Brake Indicator</i>	•	•	•	•	•	Anti-Theft Protection (Password)	•	•	•	•	•
Backup Alarm	•	•	•	•	•	48-Hour Parts Guarantee	•	•	•	•	•

- Standard Equipment
- Optional Equipment
- N/A





# WHO IS DOOSAN?

Doosan is the fifth largest construction equipment manufacturer in the world with a heritage that goes back more than 115 years. We deliver solid machines, unsurpassed customer service and an expanding dealer network plus our unrivaled 48-hour parts guarantee.

*Doosan Delivers*

[www.doosanequipment.com/WL](http://www.doosanequipment.com/WL)

1.877.613.7970



Printed on 10% recycled paper

Doosan and the Doosan logo are registered trademarks of Doosan Corp. in the United States and various other countries around the world. ©2013 Doosan Infracore Construction Equipment America. All rights reserved.